

# NOTES

All dimensions in millimetres.

This access is for vehicular use only. Should provision be required for pedestrians see Drg. Nos. 11313 and 11315.

Dimension "A" is the width of the access.

Dimension "W" is the width of the drop crossing.

Dropper kerbs and dropped kerbs may be mitred full size kerbs or special units.

Mitred kerbs shall be pointed with designation (i) mortar.

Where the access is to an individual dwelling it shall be constructed to the adjacent footway specification.

Kerb upstand, access levels and crossfall to be as shown unless indicated otherwise.

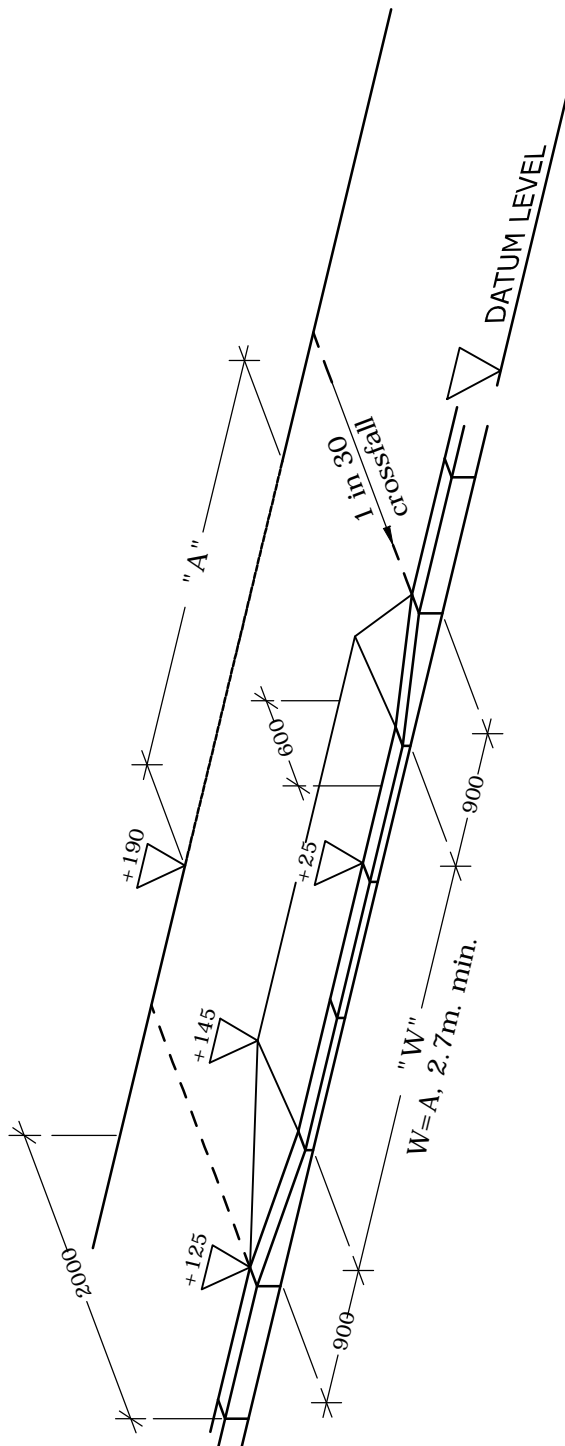

TYPICAL DETAILS FOR 2m. FOOTWAY