

# NOTES

All dimensions in millimetres.

Material ① to be well compacted acceptable material.

Concrete surround shall be mix ST2 concrete 150mm. thick, formed to radius, batter or horizontal surface.

The concrete surround may extend to the sides of the trench, or be of minimum width. Acceptable material is to be used to fill any voids so formed.

On pipelines with flexible joints a joint filler board shall be placed in contact with the end of the socket at a pipe joint. Joints shall be at intervals not exceeding 5 metres. The ingress of cement to the joint shall be prevented by wrapping with polythene or adhesive tape.

When non rigid pipelines have a section with concrete surround, a flexible joint or coupler must be provided to allow angular deflection between the non rigid and rigid components.

The minimum or maximum width of trench applies on and below a line 300mm. above the outside top of the pipe. If trench widths in excess of those specified are used, consideration will have to be given to greater pipe strengths due to increased backfill loadings.

Pipes to be centred in trench.

All joints shall be watertight.

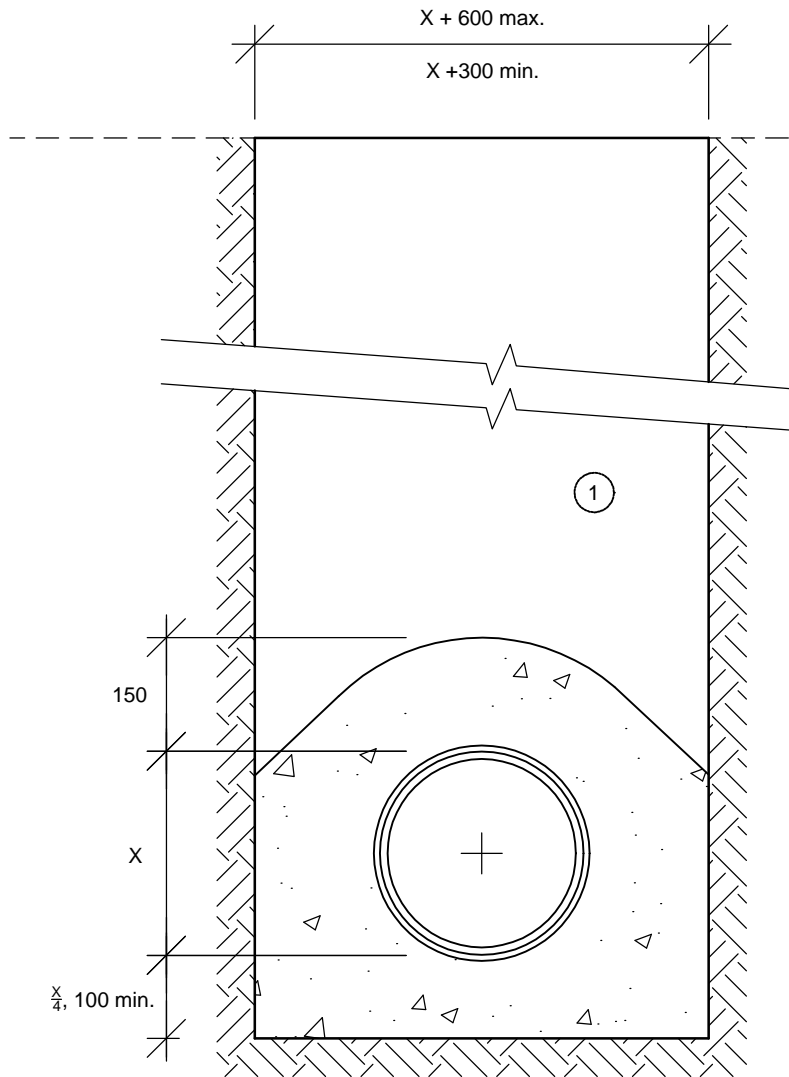

Bed Type Z  
CONCRETE SURROUND

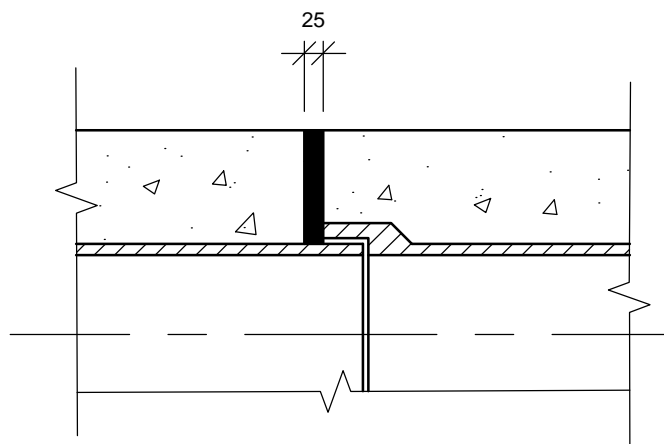

DETAIL OF EXPANSION JOINT  
FOR CONCRETE SURROUND